

Operating instructions and spare parts list

Edition 02/2020

Ahlmer Metering Unit

DSG 160

Item no. 100-00



Manufacturer:

Ahlmer GmbH & Co. KG

Schildarpstraße 20

48712 Gescher

Tel.: 02542 / 917917-0

Fax: 02542 / 917917-29

Homepage: www.amg-gmbh.com

E-mail: info@amg-gmbh.com

Operating instructions for Ahlmer

The AHLMER metering system is a robust, high-performance unit for the application of non-corrosive acids (preservatives) and silage additives based on lactic acid bacteria.

**The unit is not suitable for
the application of corrosive preservatives.**

The unit is delivered completely assembled and ready to be connected to an existing 12 V power supply.

Connections from the pump outlet to the nozzle must also be established. The required parts are included in the delivery.

Plastic containers are suitable as storage containers for the silage agents.

60-litre, 100-litre or 200-litre containers with a support frame can be obtained from AHLMER.

All other plastic containers may be used provided that they are thoroughly cleaned. A small hole should be made in the container cover for venting.

Delivered items:

- Pump with mounting bracket
- Filter unit with connections
- Nozzles with holders
- Hoses, hose clamps and inlet valve
- Electrical terminal box, cable, cord switch
- Operating instructions

Dimensions approx DSG 160: W x H x D: 30 cm x 45 cm x 12 cm

Dimensions approx 160/60 ca.: B x H x T: 77 cm x 64 cm x 40 cm

Dimensions approx 160/100 ca.: B x H x T: 80 cm x 75 cm x 50 cm

Dimensions approx 160/200 ca.: B x H x T: 95 cm x 90 cm x 60 cm

Rinse with water every day after use!

There is no claim to compensation for damage to the unit resulting from improper use or use of other acids.

Mounting:

The metering units is attached to the harvester using the bracket delivered. The mounting must be vertical.

The reservoir should be placed in the immediate vicinity of the pump as the pump can only draw against a vertical head of 1.5 metres.

A hole must be drilled in the reservoir cover through which the suction hose (fabric hose 2 m long) is passed.

The supplied foot valve with suction filter is also attached to this hose. Make sure that the hose always reaches to the bottom of the reservoir.

A hose line is also required from the hose connection on the mass flow indicator to the nozzles.

Power supply:

Connect the electric cable to the battery or to the 12 V socket of the harvester.

Blue cable	+ (power supply)
Brown cable	- (ground)

Connect the cord switch supplied to the cable provided (3 m long). Attach the cord switch to the pick-up of the harvester. **If a pick-up signal is present this is connected to the blue cable (in this case the brown cable remains free).**

The power is switched on and off using the switch provided on the unit's control box. Switching on and off during operation by means of a cord switch. A fuse (5 amp) is provided in the unit's control box.

A pressure switch is located on the pump to protect the pump from damage. The pump is automatically switched off if the pressure in the pressure line rises above 1.5 bar. The pump switches back on once the pressure drops below 1.5 bar.

Attaching the nozzles:

One set of nozzles is included in the standard pump delivery.

The nozzles can be easily attached to any desired location on the harvester using the nozzle holder provided.

Place the nozzle(s) in the vicinity of the harvester's intake ensuring that the chopped material is thoroughly sprayed.

When attaching the nozzle(s), make sure that the nozzle(s) do not come into contact with crop or the harvester's intake machinery.

After successful attachment, secure all of the hose connections with hose fitting to prevent leaks.

It is advisable to check the set metered quantity before starting work!

Place the nozzle(s) in a bucket and run silage agent through the pump for one minute. Determine the exact quantity with a litre gauge and compare it with the set metered quantity. Adjust if necessary.

The pump flow rate is set using the speed controller.

The float rises or falls in the flow indicator depending on the setting. This indicates the quantity delivered in litres per hour.

Functional description:

The pump starts to run after it is connected to the power by actuating the switch on the control box and actuating the cord switch.

To ensure proper function, it is advisable to fill the pump with water before first use.

This is only necessary when starting for the first time.

The float rises in the flow indicator and indicates the quantity being processed in litres per hour.

The settings may have to be adjusted depending on the concentration of the solution being metered and its current viscosity. These settings must be determined by metering.

The quantity can be altered by adjusting the speed controller.

Caution!

The unit should be rinsed with water after a long period of use and when idling for a longer period.

To protect the unit from frost it is necessary to completely empty the unit or to fill the unit with an antifreeze solution.

The manufacturer accepts no liability for any damage that occurs as a result of not observing this functional description!

Checklist for elimination of faults

Fault	Cause	Elimination
Pump does not draw	<ul style="list-style-type: none"> • Suction line or filter is blocked • The interior of the pump housing is dirty • The lines contain too much air 	<ul style="list-style-type: none"> • Clean the suction line and valve • Clean the filter • Clean the pump housing
Pump delivers a lot of air	<ul style="list-style-type: none"> • Container is empty • Suction line is leaking 	<ul style="list-style-type: none"> • Fill or change the container • Eliminate leaks in the suction line by tightening the hose clips and sealing threads with sealing tape
Motor doesn't run	<ul style="list-style-type: none"> • The system is switched off • Power cable is loose • Motor is defective • Remote switch is defective or the solenoid is (too far) away • Fuse has blown 	<ul style="list-style-type: none"> • Switch the system on • Check the cable • Replace the motor • Replace the switch • Replace the fuse
Pressure and flow are too low	<ul style="list-style-type: none"> • Pump or lines are leaking • Suction or pressure line is blocked 	<ul style="list-style-type: none"> • Eliminate leaks in the pump or lines • Clean the lines
Pump shuts down	<ul style="list-style-type: none"> • Pressure switch has triggered • Nozzle diameter too small for large flow quantity 	<ul style="list-style-type: none"> • Fit larger nozzles

Mixing table

Metering l/t	Quantity of water per container l	Container per 200 l (water) pieces	Metering solution 200 l for t
0.5	25	8	400
1.0	50	4	200
2.0	100	2	100

Selection of nozzle

The LACTO-SPRAYER JUNIOR has 12 nozzles as standard. These consist of 2 x orange, green, yellow, blue, red and brown.

Example of a nozzle selection for 110 l/h:

1 x yellow + 1 red

Tab.: Nozzle capacity in litres per hour at various pressures

XR-Teejet	FROM 1 bar	TO 4 bar
Orange	13,8	27
Green	20,4	40,8
Yellow	27,6	54,6
Blue	40,8	81,6
Red	54,6	109,2
Brown	68,4	136,2
Grey	82,2	164,4
White	109,2	219

Specification taken from the technical data sheet. The ACTUAL quantity may differ

Note: metering of non-corrosive acids:

!!! The image of the flow unit shown here is incorrect !!!

Method:

1. Pre-selection of nozzles according to the table (metering line is reduced by approx. 20 - 30%!)
2. Metering with the silage additives

DSG 160 (Item No. 100-00)
Bracket, pump, filter, flow indicator

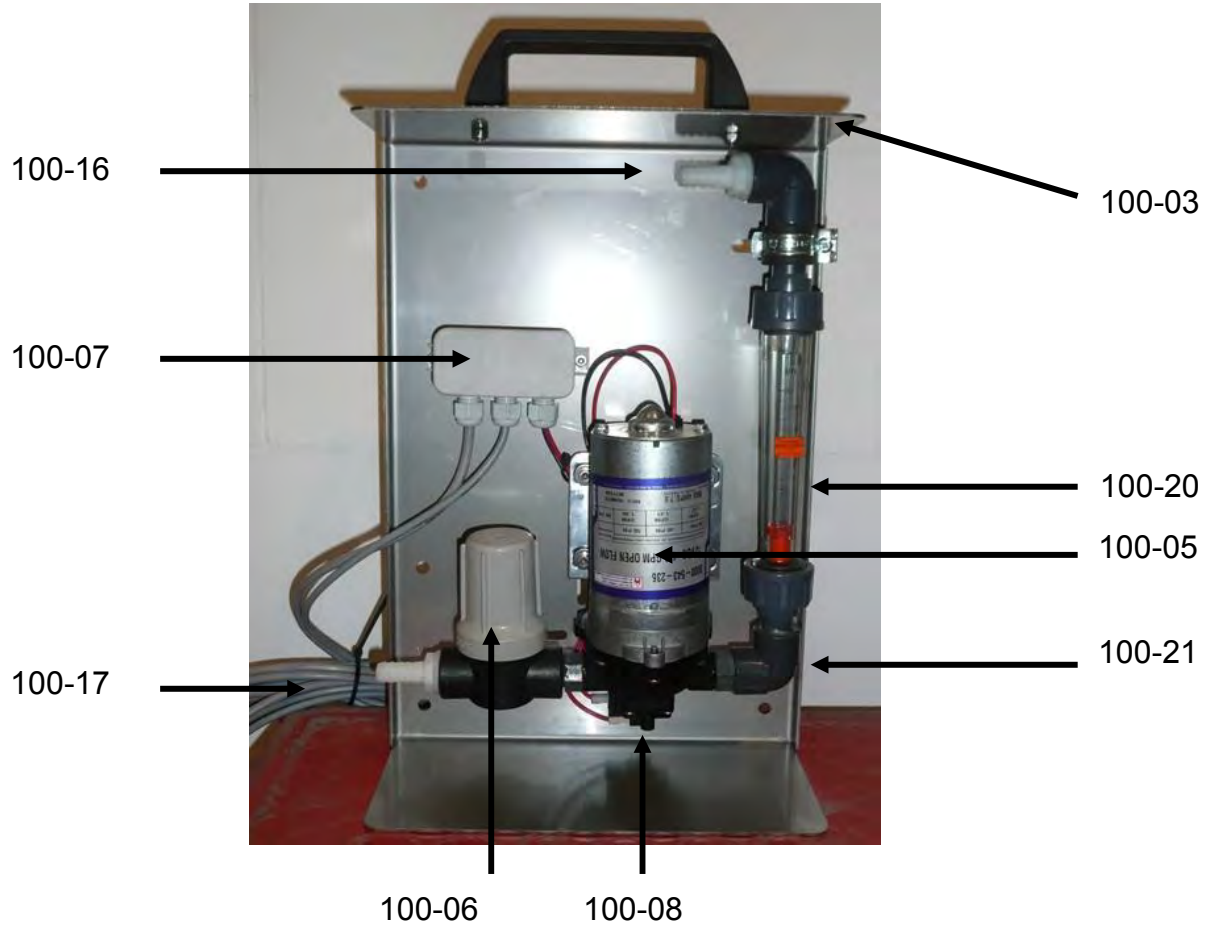

- | | |
|------------------------|---------------------------|
| Item no. 100-03 | Mounting bracket |
| Item no. 100-05 | Pump |
| Item no. 100-06 | Suction filter - complete |
| Item no. 100-07 | Terminal box |
| Item no. 100-08 | Pressure switch |
| Item no. 100-16 | Upper hose connection |
| Item no. 100-17 | Cable set |
| Item no. 100-20 | Sight glass with float |
| Item no. 100-21 | Lower hose connection |

DSG 160

The Dosistar electronic speed adjuster (Item no. 10-00)

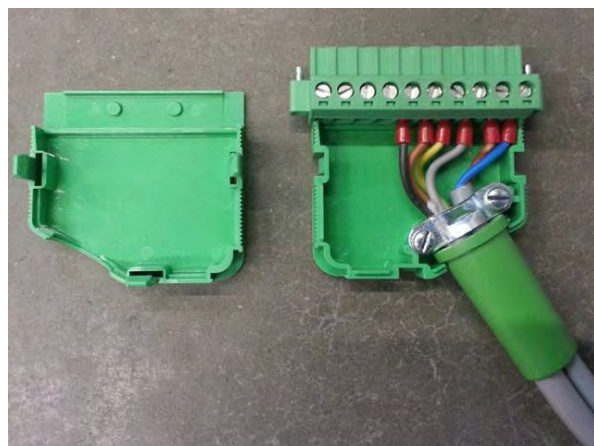
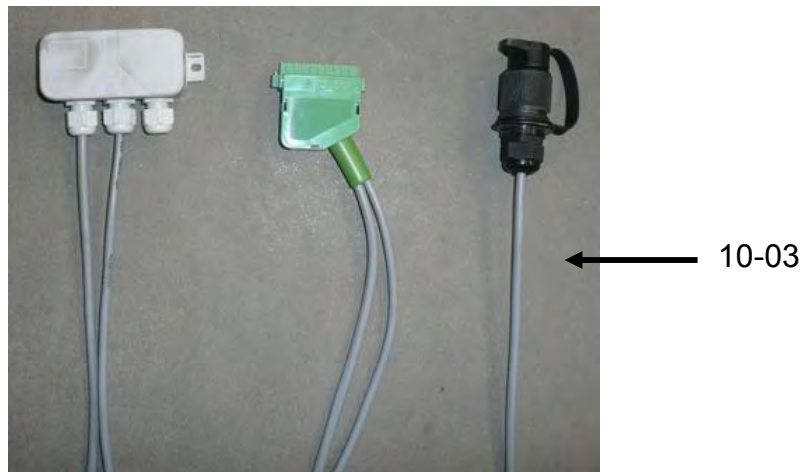
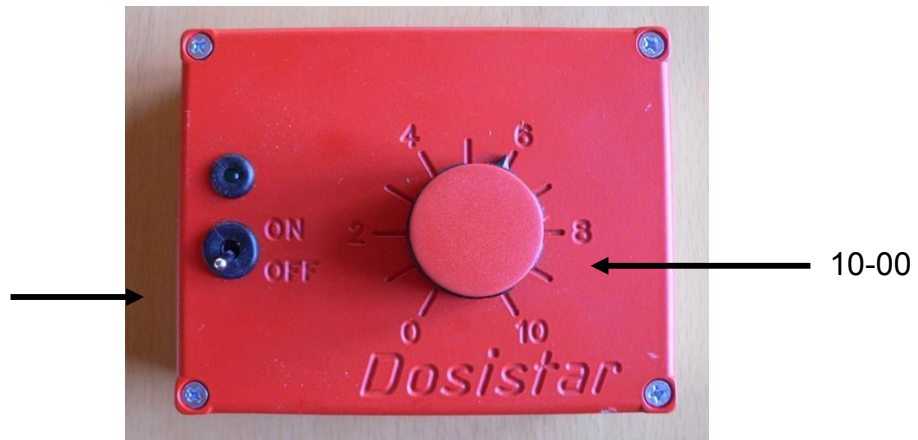

Item no. **10-00**

Dosistar-V

Item no. **10-03**

Cable set complete

Diagram DSG 160

Connector:

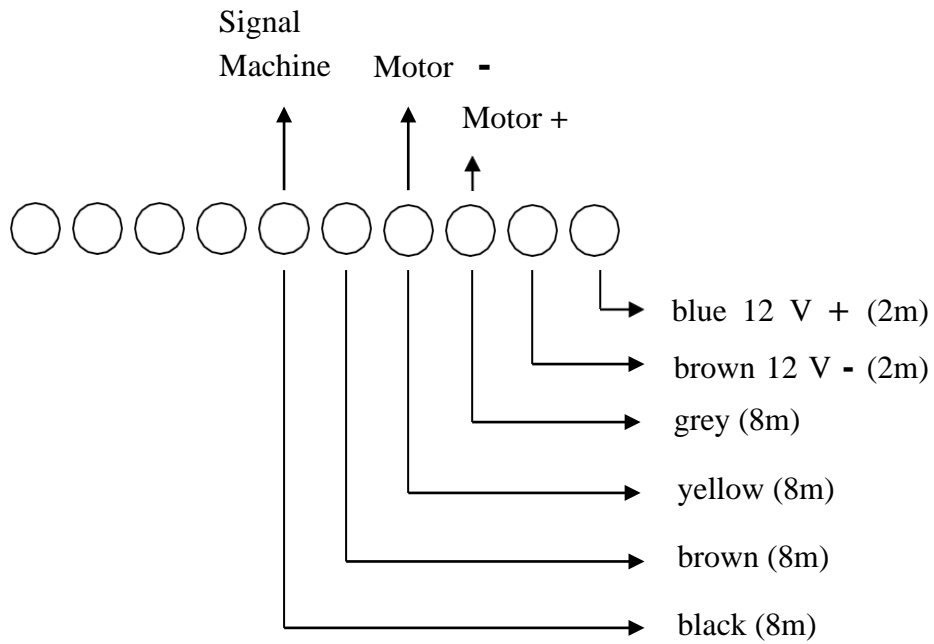

Junction box

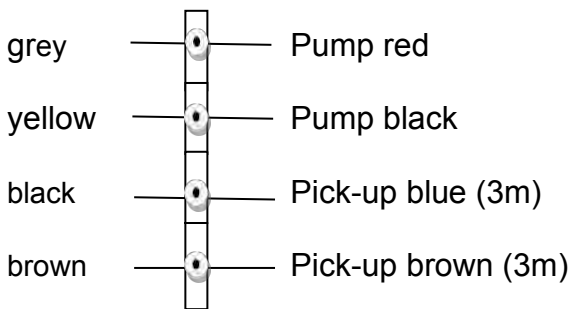

DSG 160

Flow indicator complete Item no. 100-19

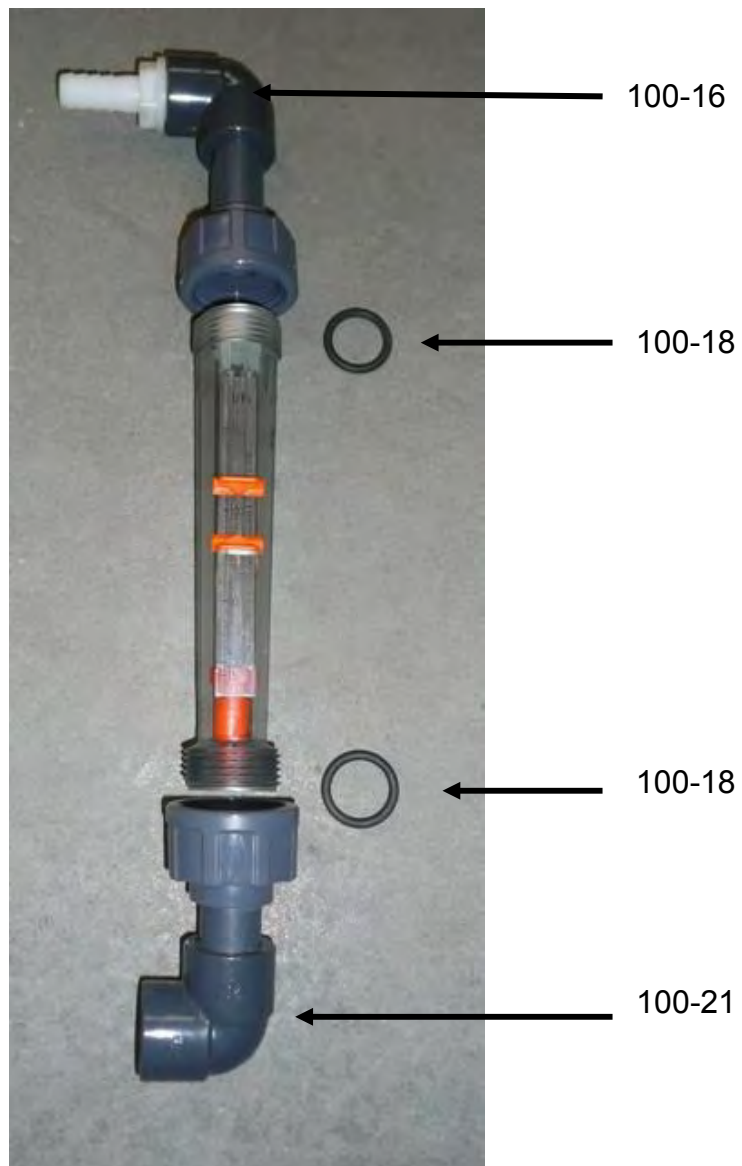

Item no. **100-16**

Upper hose connection

Item no. **100-18**

O-ring

Item no. **100-19**

Flow meter DFM 170 complete

Item no. **100-20**

Sight glass with float and O-rings

Item no. **100-21**

Lower hose connection

DSG 160

Suction filter complete (Item no. 100-06)

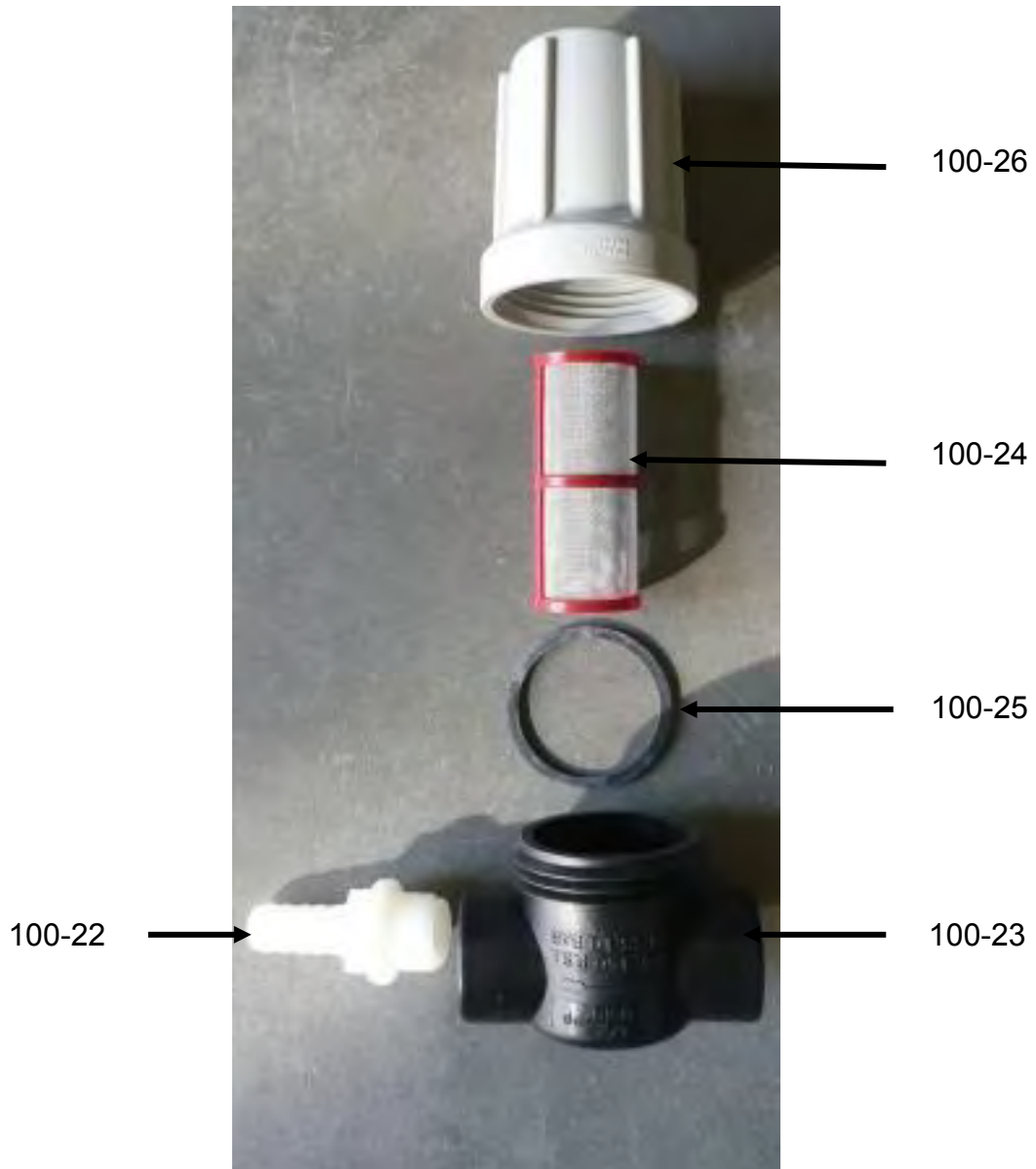

- Item no. **100-06** Suction filter - complete
- Item no. **100-22** Hose connection
- Item no. **100-23** Filter housing
- Item no. **100-24** Filter insert
- Item no. **100-25** O-ring
- Item no. **100-26** Filter cup

DSG 160

Nozzle set

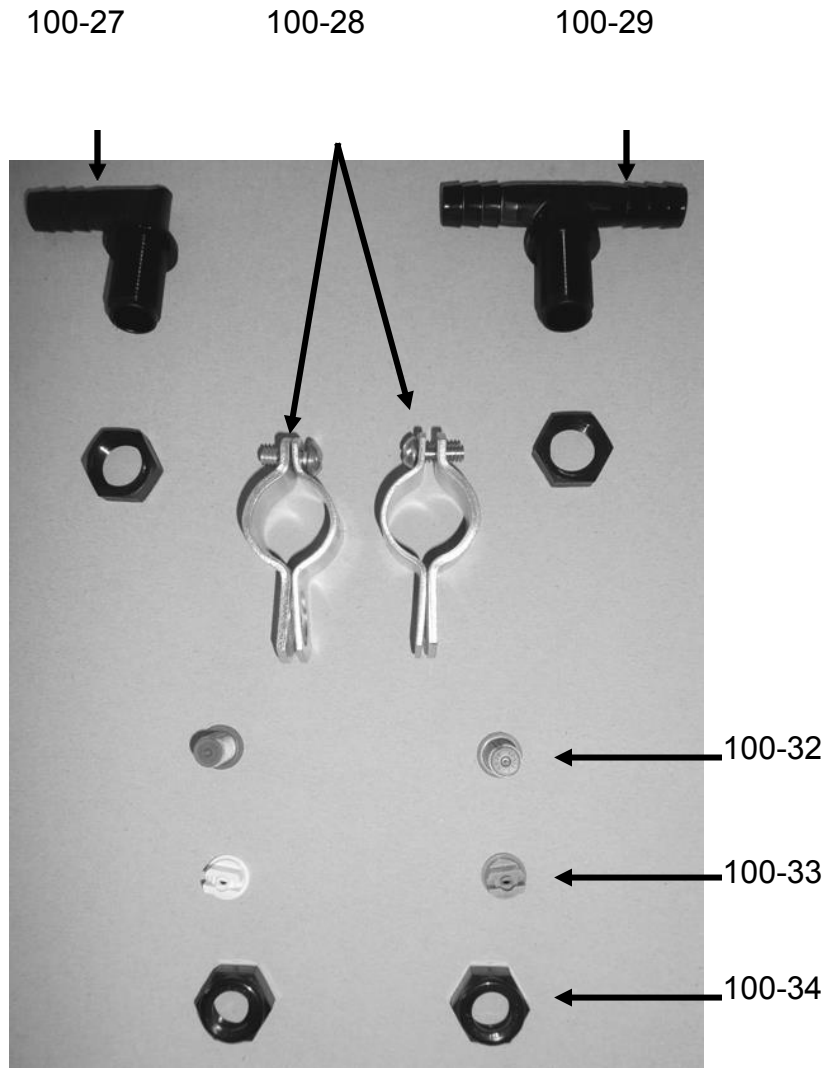

Item no. 100-27-k Nozzle holder angle complete **Item no. 100-29-k Nozzle holder T-piece complete**
consisting of: **consisting of:**

Item no. 100-27	Nozzle holder angle incl. union nut	Item no. 100-29	Nozzle holder T-piece incl. union nut
Item no. 100-28	Mounting clip	Item no. 100-28	Mounting clip
Item no. 100-32	Drip protection	Item no. 100-32	Drip protection
Item no. 100-33	Nozzle insert	Item no. 100-33	Nozzle insert
Item no. 100-34	Nozzle clamping nut	Item no. 100-34	Nozzle clamping nut

Item no. 19-010	Nozzle insert, diameter 0,10 mm, Colour: orange
Item no. 19-015	Nozzle insert, diameter 0.15 mm, Colour: green
Item no. 19-020	Nozzle insert, diameter 0.20 mm, Colour: yellow
Item no. 19-030	Nozzle insert, diameter 0.30 mm, Colour: blue
Item no. 19-040	Nozzle insert, diameter 0.40 mm, Colour: red
Item no. 19-050	Nozzle insert, diameter 0.50 mm, Colour: brown
Item no. 19-060	Nozzle insert, diameter 0.60 mm, Colour: grey
Item no. 19-080	Nozzle insert, diameter 0.80 mm, Colour: white

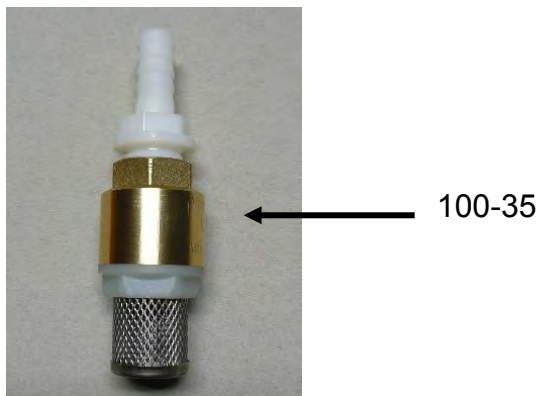

Item no. **100-35E** Foot filter check valve